

PLATAFORMA ELEVADORA SOBRE MASTIL MAST CLIMBING WORK PLATFORM

GP40

De acuerdo con las directivas y normas / According to the following directive and standards

Directiva Máquinas	2006/42/CE	Directive on Machinery
Directiva de Baja Tensión	2014/35/UE	Low Voltage Directive
Directiva de Compatibilidad Electromagnético	2014/30/UE	Electromagnetic Compatibility Directive
Plataforma elevadora sobre mástil	EN 1495	Mast Climbing Work Platforms
Seguridad de Máquinas	EN 12100	Safety of machinery
Seguridad de máquinas. Equipo eléctrico	EN 60204-1	Safety of machinery – Electric equipment



MAX. CARGA / MAX. LOAD
2300 Kg

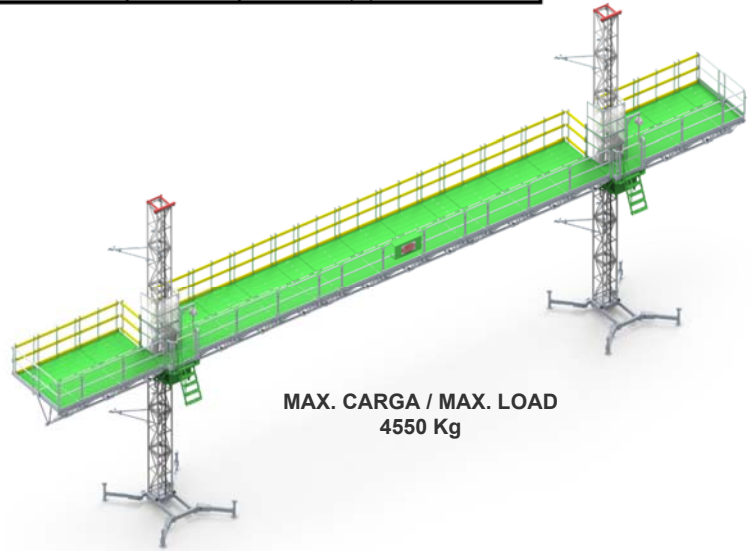

MAX. CARGA / MAX. LOAD
4550 Kg

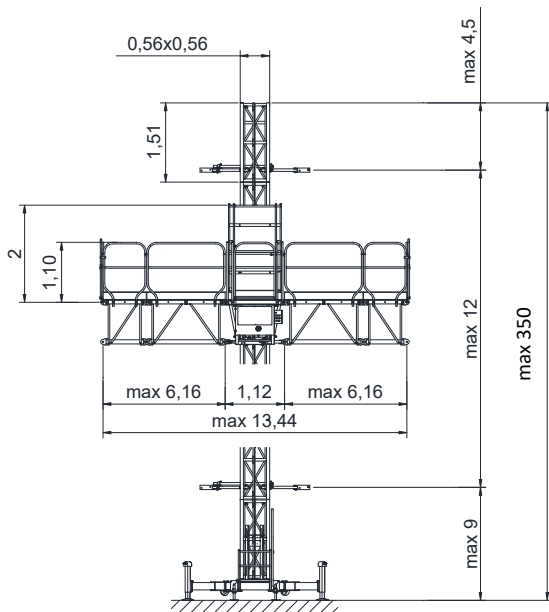

CONFIGURACIONES BASE / BASE FRAME CONFIGURATIONS

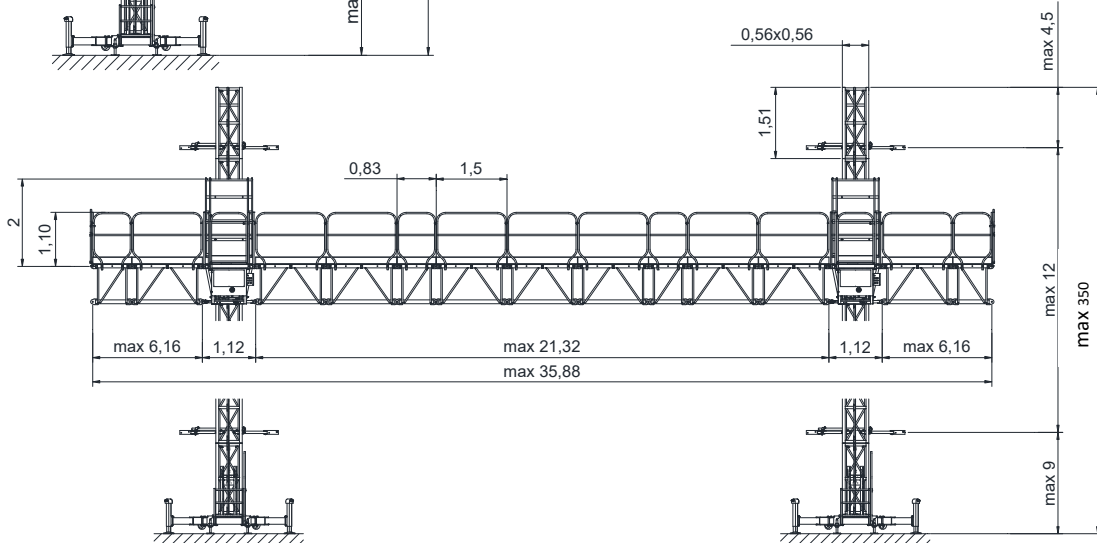
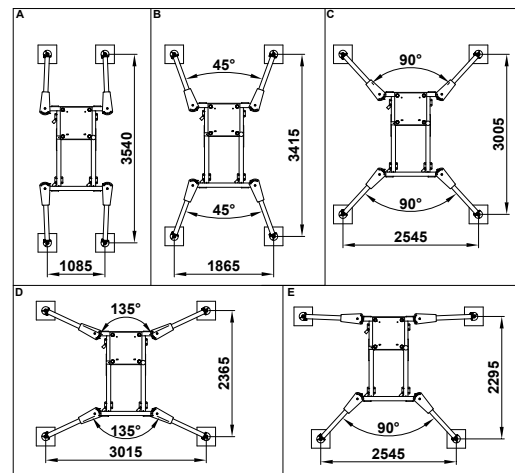

Date / Date: 05/09/2022

Reservado el derecho a modificaciones sin previo aviso. Declinamos toda responsabilidad derivada de la información proporcionada.
Subject to modification, without previous warning This document is supplied without liability.

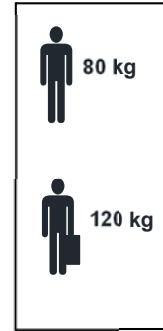
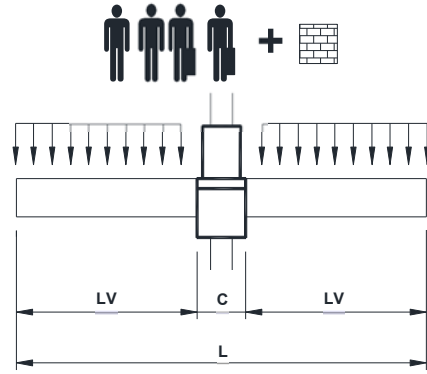

M	Monomástil / Single Mast			Max. capacidad de carga Max. load capacity	
L	VL	C	LV		
2,78 m	1 x 0,83	1,12 m	1 x 0,83	2300 Kg	
4,12 m	1 x 1,5	1,12 m	1 x 1,5	2200 Kg	
5,78 m	1 x 1,5 + 1 x 0,83	1,12 m	1 x 1,5 + 1 x 0,83	2050 Kg	
7,12 m	2 x 1,5	1,12 m	2 x 1,5	1950 Kg	
8,78 m	2 x 1,5 + 1 x 0,83	1,12 m	2 x 1,5 + 1 x 0,83	1800 Kg	
10,12 m	3 x 1,5	1,12 m	3 x 1,5	1700 Kg	
11,78 m	3 x 1,5 + 1 x 0,83	1,12 m	3 x 1,5 + 1 x 0,83	1050 Kg	
13,44 m	3 x 1,5 + 2 x 0,83	1,12 m	3 x 1,5 + 2 x 0,83	850 Kg	

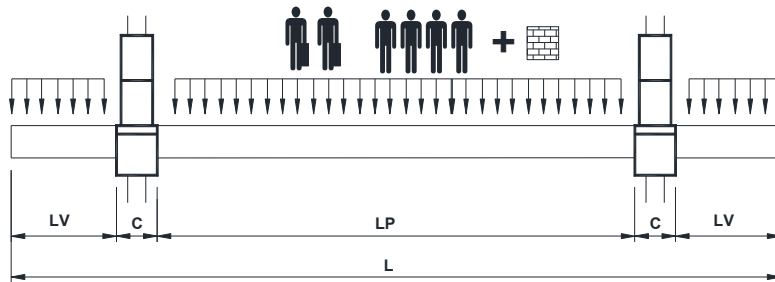

M	Bimástil / Twin Mast				Max. capacidad de carga Max. load capacity	
L	VL	C	LP	LV		
8,4 m	1 x 0,83	2 x 1,12 m	3 x 1,5	1 x 0,83	4550 Kg	
11,4 m	1 x 1,5 + 1 x 0,83	2 x 1,12 m	3 x 1,5	1 x 1,5 + 1 x 0,83	4300 Kg	
17,4 m	2 x 1,5	2 x 1,12 m	5 x 1,5 + 2 x 0,83	2 x 1,5	3800 Kg	
20,4 m	3 x 1,5	2 x 1,12 m	5 x 1,5 + 2 x 0,83	3 x 1,5	3550 Kg	
23,56 m	3 x 1,5	2 x 1,12 m	6 x 1,5 + 4 x 0,83	3 x 1,5	3350 Kg	
26,56 m	3 x 1,5	2 x 1,12 m	8 x 1,5 + 4 x 0,83	3 x 1,5	3100 Kg	
29,56 m	3 x 1,5	2 x 1,12 m	10 x 1,5 + 4 x 0,83	3 x 1,5	2800 Kg	
31,06 m (*)	3 x 1,5	2 x 1,12 m	11 x 1,5 + 4 x 0,83	3 x 1,5	2200 Kg	
32,56 m (*)	3 x 1,5	2 x 1,12 m	12 x 1,5 + 4 x 0,83	3 x 1,5	2100 Kg	
32,88 m (*)	3 x 1,5 + 2 x 0,83	2 x 1,12 m	10 x 1,5 + 4 x 0,83	3 x 1,5 + 2 x 0,83	2000 Kg	
34,38 m (*)	3 x 1,5 + 2 x 0,83	2 x 1,12 m	11 x 1,5 + 4 x 0,83	3 x 1,5 + 2 x 0,83	1800 Kg	
35,88 m (*)	3 x 1,5 + 2 x 0,83	2 x 1,12 m	12 x 1,5 + 4 x 0,83	3 x 1,5 + 2 x 0,83	1700 Kg	

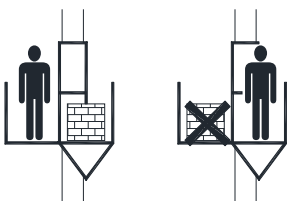

La carga tiene que estar uniformemente repartida a lo largo de la plataforma y nunca en las zonas de las extensiones.
The load must be evenly distributed on the platform deck and never laid on the extension area.



Fecha / Date: 05/09/2022

Reservado el derecho a modificaciones sin previo aviso. Declinamos toda responsabilidad derivada de la información proporcionada.
Subject to modification, without previous warning This document is supplied without liability.

		MONOMASTIL SINGLE MAST	BIMASTIL TWIN MAST
Longitud máxima de la plataforma	<i>Maximum platform length</i>	13,44 m	35,88 m
Longitud mínima de la plataforma	<i>Minimum platform length</i>	2,78 m	4,73 m
Longitud máxima puente central	<i>Central deck maximum length</i>	-	21,32 m
Anchura de la plataforma	<i>Platform width</i>	1,3 m	
Anchura máxima extensión telescópica	<i>Maximum telescopic extension width</i>	1 m / 1,5 m / 2 m [*]	
Altura máxima autoestable	<i>Maximum lifting height (freestanding)</i>	9 m	
Altura máxima con anclajes	<i>Maximum lifting height (anchored)</i>	350 m [*]	
Máxima distancia entre anclajes	<i>Maximum distance between ties</i>	12 m	
Velocidad de elevación	<i>Lifting speed</i>	6 m/min / 12 m/min [**]	
Longitud de modulo plataforma	<i>Deck module length</i>	1,5 m / 0,83 m	
Numero máximo de personas	<i>Maximum number of persons</i>	4	6
Velocidad máxima en servicio. Anclado	<i>Maximum allowed wind speed during service. Anchored</i>	55 km/h	
Módulo de mástil	<i>Mast section</i>	1,5 m	

CARACTERÍSTICAS ELÉCTRICAS / ELECTRICAL DATA

Potencia de motores de elevación	<i>Rated power drive units</i>	2 x 1,5 kW 2 x 3 kW [**]	4 x 1,5 kW 4 x 3 kW [**]
Conexión eléctrica 50 Hz	<i>Input power range 50 Hz</i>	400 V	
Conexión eléctrica 60 Hz	<i>Input power range 60 Hz</i>	480 V kW + 20% m/min + 20%	
Potencia requerida	<i>Power supply</i>	5,5 kVA / 10,5 kVA	10,5 kVA / 20,5 kVA

[*] Para valores superiores a 150 m consultar a / For higher values of 150 m please contact JASO EQUIPOS DE OBRAS Y CONSTRUCCIONES, S.L.

[**] Opcional / Optional

DISPOSITIVOS DE SEGURIDAD / SAFETY DEVICES

Dos motorreductores por mástil con freno electromecánico	<i>Two geared motors per mast with electromechanical brake</i>
Dos frenos centrífugos paracaídas de emergencia	<i>Overspeed emergency brakes</i>
Sistema de nivelación horizontal automática	<i>Automatic horizontal regulation system</i>
Descenso manual de emergencia	<i>Emergency manual descending</i>
Puertas de acceso con enclavamiento eléctrico	<i>Access doors with closed limit switch</i>
Protector de mástil	<i>Mast protector</i>
Finales de carrera para límites de recorrido superior e inferior	<i>Limit switches for maximum and minimum height</i>
Detector de presencia de cremallera	<i>Rack detector limit switch</i>
Amortiguadores en la base y en la punta del mástil	<i>Shock absorbers at the base and at the top of the mast</i>
Señal acústica de maniobra	<i>Manoeuvre acoustic signal</i>
Piso antideslizante	<i>Non-sliding floor</i>
Grupo tractor diseñado específicamente para garantizar una óptima transmisión de potencia y una seguridad plena	<i>Full safety tractor group with specific design to provide an optimal power transfer</i>
Tope mecánico límite superior	<i>Mechanical stop at the top of the last mast</i>
Tensión de maniobra 24V AC	<i>Control voltage 24V AC</i>



OPCIONAL / OPTIONAL

Pisos metálicos extensión	<i>Metallic floor extensions</i>
Pescante + Polipasto montaje	<i>Booms and hoist assembly</i>
Cubo guardamanguera	<i>Cable storage bucket</i>
Kit esquinero	<i>Right-angle corner kit</i>
Kit detección obstáculos	<i>Obstacle detection kit</i>
Extensión Unidad motriz ≤ 1m	<i>Power unit floor extension</i>
Base dimensiones reducidas	<i>Reduced space base</i>
Tope mecánico inferior flotante	<i>Floating mechanical buffer stop (lower)</i>
Red anti proyección	<i>Debris safety net</i>
Anemómetro	<i>Anemometer</i>
Dispositivo seguridad paracaídas (3kW)	<i>Emergency anti-fall braking system</i>
Dispositivo detector de sobrecarga	<i>Overload detector</i>

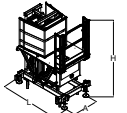
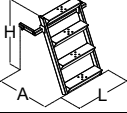
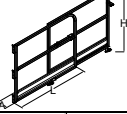
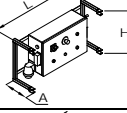
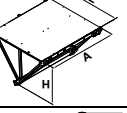
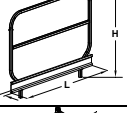
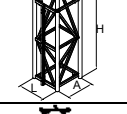

Fecha / Date: 05/09/2022

Reservado el derecho a modificaciones sin previo aviso. Declinamos toda responsabilidad derivada de la información proporcionada.
Subject to modification, without previous warning This document is supplied without liability.

DENOMINACIÓN / DENOMINATION		L (mm)	A (mm)	H (mm)	P / W (Kg)
Grupo motor <i>Drive unit</i>		1818	1220	2400	1129
Escalera de acceso <i>Access ladder</i>		692	978	1099	24
Barandilla lateral telescópica <i>Telescopic lateral guard-rail</i>		1434	106	1181	26
Armario eléctrico <i>Electrical control cupboard</i>		960	276,5	509	36
Módulo de plataforma 1,5 m / <i>1,5 m deck module</i> Módulo de plataforma 0,83 m / <i>0,83 m deck-module</i>		1400 1400	1580 910	750 750	100 65
Barandilla 1,5 m / <i>1,5 m Guard-rail</i> Barandilla 0,83 m / <i>0,83 m Guard-rail</i>		1490 820	50 50	1215 1215	11 7
Mástil 1,5 m <i>1,5 m mast section</i>		600	560	1508	S 78 R 92
Arriostramiento <i>Wall tie</i>		Min. 300 Max. 1600	Min. 300 Max. 1600	-	25

TRANSPORT E / TRANSPORT

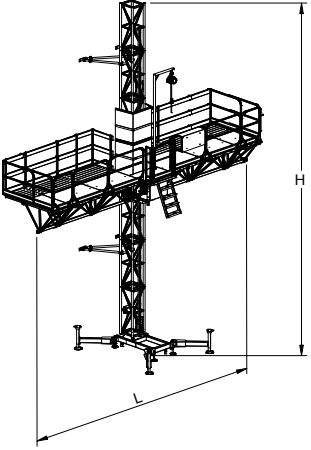
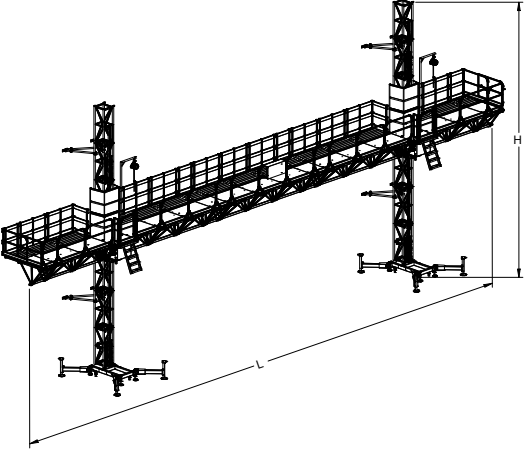
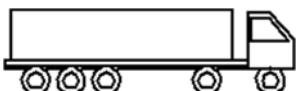
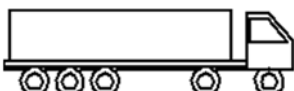
			
1x  L = 13,44 m H = 120 m	1x  L = 35,88 m H = 36 m		
1x <table border="1" data-bbox="454 1825 694 1892"> <tr> <td>HIGH CUBE 40'</td> </tr> </table> L = 13,44 m H = 96 m	HIGH CUBE 40'	2x <table border="1" data-bbox="1189 1825 1428 1892"> <tr> <td>HIGH CUBE 40'</td> </tr> </table> L = 35,88 m H = 90 m	HIGH CUBE 40'
HIGH CUBE 40'			
HIGH CUBE 40'			

Transporte por contenedor / *Transport by container*



Ctra./Rd. Madrid - Irún Km. 415 - 20.213 IDIAZABAL [Gipuzkoa] ESPAÑA / SPAIN
 P.O. Box, 23 - 20.200 BEASAIN - E-mail: jaso@jaso.com
 Tel. +34 943 - 18 70 00 • Fax. +34 943 - 18 70 20
www.jaso.com

Fecha / Date: 05/09/2022

Reservado el derecho a modificaciones sin previo aviso. Declinamos toda responsabilidad derivada de la información proporcionada.
 Subject to modification, without previous warning This document is supplied without liability.

DELEGACIÓN / DEALER